

# ROD-OUT DEVICE

MAINTAIN CLEAN PROCESS SIGNAL PORTS

ISO 9001:2008 Certified Quality System

## User-Friendly

Power Drill Operated  
for Maximum Clean-  
Out Power and Ease  
of Operation

Integrated Bleed Port  
and Gauge Port

Rod Out Under  
Pressure

Offered in Both  
Grafoil® and Teflon®

Various Larger  
Cutters Available

Various Longer Rod  
Lengths Available

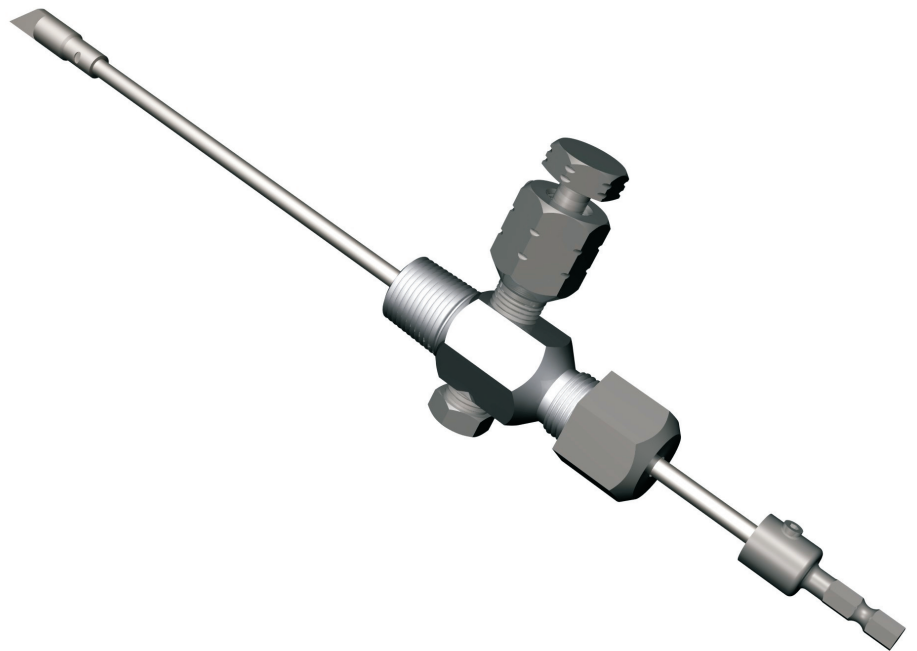

**PGI International**

*Excellence Through Innovation*

# ROD-OUT DEVICE

## Part Number Selection

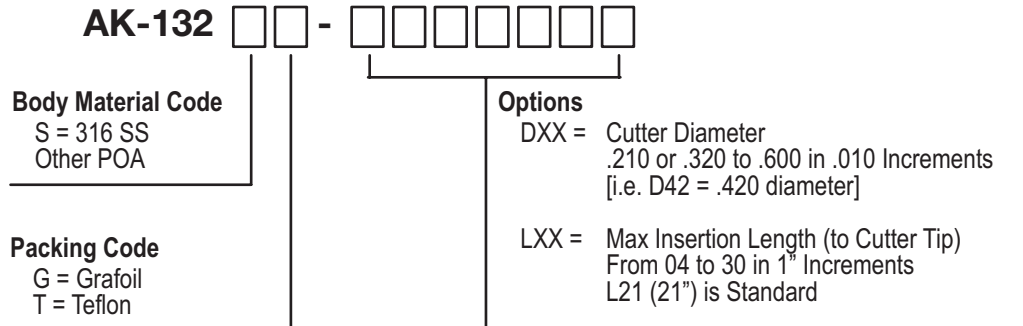

## Specifications

**Grafoil®**  
 1000 PSI @ 1000°F Max

**Teflon®**  
 1500 PSI @ 450°F Max

**Cutter, Drill Adapter & Rod**  
 All 174PH - H900

## Sectional View

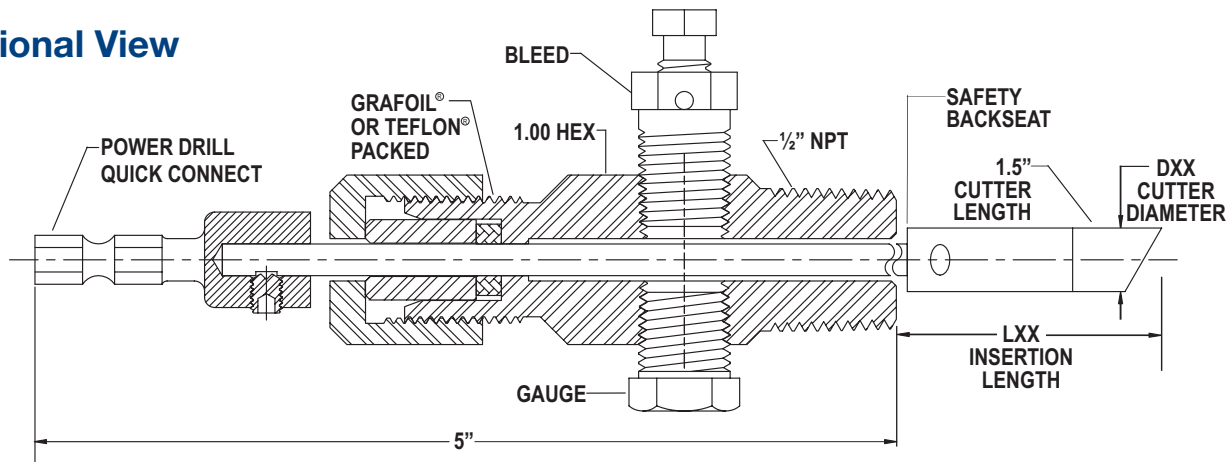

PGI International provides this information in good faith, and it is intended only as an informative guide to PGI International products and services. Individuals using this literature must exercise their independent judgment in evaluating product selection and determining product appropriateness for their particular purpose, system requirements and certifications. PGI International reserves the right to change product designs and specifications without notice.



**PGI International**  
 Excellence Through Innovation

16101 Vallen Drive • Houston, TX 77041 USA  
 713-466-0056 • 1-800-231-0233 • Fax: 1-800-568-9228  
 sales@pgiint.com • www.pgiint.com