



2-Valve Static Pressure M-800 Series Manifold *2-1/8" Centers*

HARD SEAT
1/2" FNPT x FLANGE

HARD BALL SEAT: .125" Orifice



Features

- PGI Standard 316 SS Ball Seat

Benefits

- Non-rotating ball eliminates seat galling and ball creasing
- Leak free, bubble tight seating
- Available in a variety of materials

INSTRUMENT

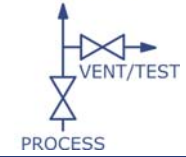

Dimensions, inches [mm]

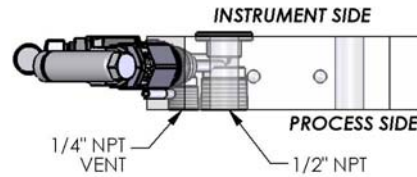
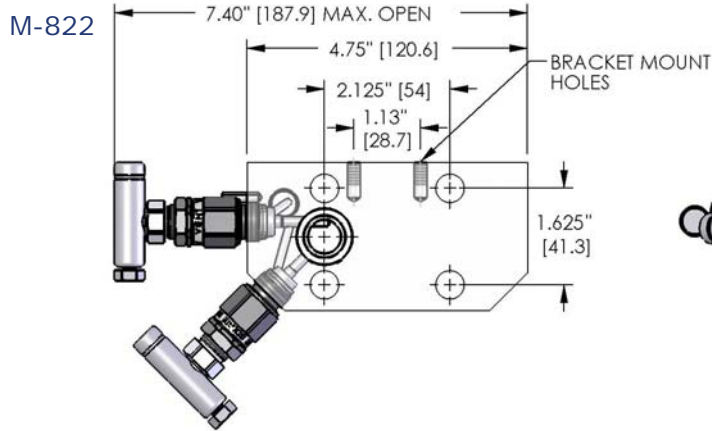

Pressure vs. Temperature

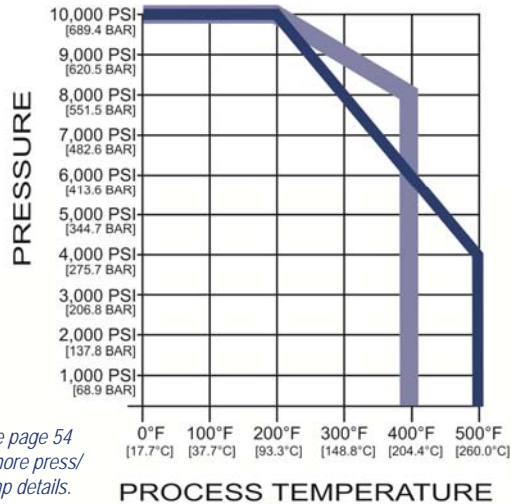

See page 54 for more press/ temp details.

Part Number Selection

Base Model

	<i>Process x Instrument x Vent/Test</i>
M-822	1/2" FNPT x Flange x 1/4" NPT

Body Material Code

S	ASTM A479-316 SS
P	ASTM A696*

Seat Material Code

6	316 SS Ball (Standard)
C	Carbide Ball
N	Monel®

Stem Packing/Seal Code

P	Teflon® (Below threads)
V	Viton® O-Ring

M-822				-	Options [pages 49-50]
-------	--	--	--	---	-----------------------

Materials of Construction

Part	A696 Carbon Steel*	316 Stainless Steel
Body / Bonnet	ASTM A696 Gr.C	ASTM A479-316
Packing "P" / "V"	Teflon®/Viton® O-Ring	Teflon®/Viton® O-Ring
Stem	ASTM A479-316	ASTM A479-316
Packing Adjuster	ASTM A696 Gr.C	ASTM A479-316
Packing Follower	ASTM A479-316	ASTM A479-316
Jam Nut (TFE Packed Only)	ASTM A696 Gr.C	ASTM A582-303
Handle Assembly	ASTM A108	300 Series SS

Max Cv Ratings

.125" Orifice	Straight Body Style
	.25

Approx. Manifold Weight:
5.20 lbs. [2.35 kg] ea.

* Barstock equivalent of ASTM A105

Notes

- PGI Carbon Steel products are Alkaline Zinc plated for corrosion prevention
- PGI 316 SS products meet the requirements of NACE MR0175/ISO 15156-3
- 100% Pressure Tested
- Carbon Steel Weld End Connection Bodies are ASTM A696 Gr.C