



3-Valve Differential Pressure Manifolds

HARD SEAT

HARD BALL SEAT: .375" Orifice



Features

- PGI Standard 316 SS Ball Seat

Benefits

- Non-rotating ball eliminates seat galling and ball creasing
- Leak free, bubble tight seating
- Available in a variety of materials

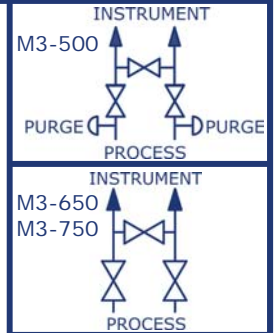

Dimensions, inches [mm]

M3-500

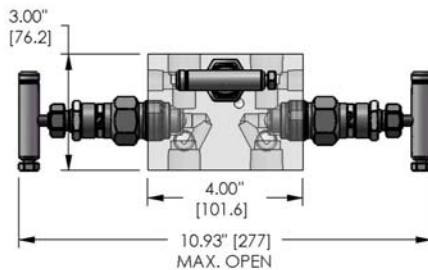

M3-650

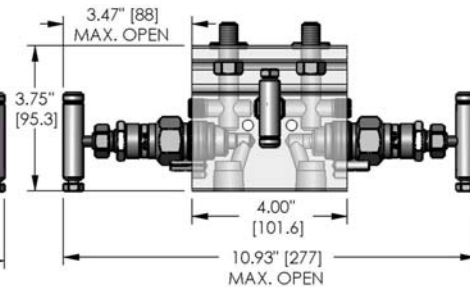

M3-750

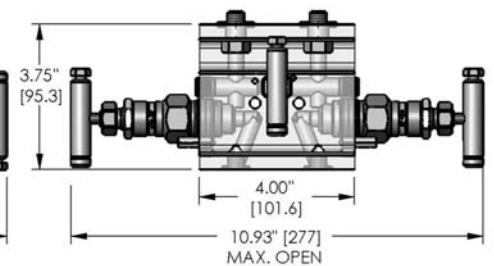

Pressure vs. Temperature

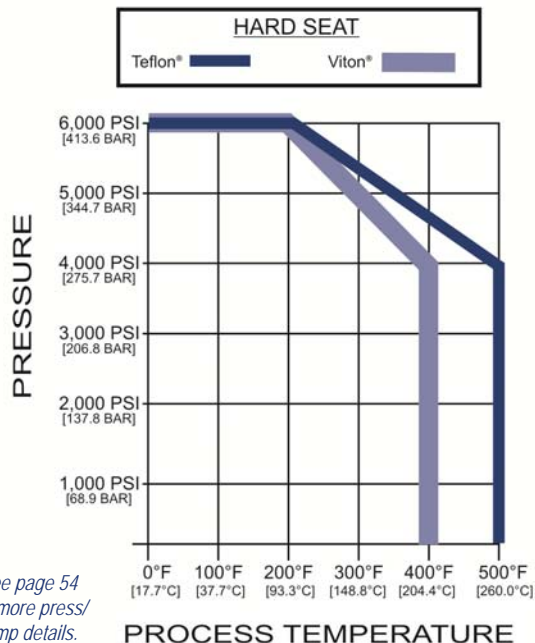

See page 54 for more press/ temp details.

Part Number Selection

Base Model

	Process x Instrument x Vent
M3- 500	1/2" FNPT x 1/2" FNPT x 1/4" NPT
M3- 650	1/2" FNPT x Flange x 1/4" FNPT
M3- 750	Flange x Flange x 1/4" NPT

Body Material Code

C	ASTM A108
S	ASTM A479-316 SS
	ASTM A276-316 SS
P	ASTM A696*

Seat Material Code

6	316 SS Ball
C	Carbide Ball
N	Monel®

Stem Packing/Seal Code

P	Teflon® (Below threads)
V	Viton® O-Ring

M3- - Options [pages 49-50]

Materials of Construction

Part	Carbon Steel	A696 Carbon Steel*	316 Stainless Steel
Body / Bonnet	ASTM A108	ASTM A696 Gr.C	ASTM A479-316 ASTM A276-316
Packing "P" / "V"	Teflon®/Viton® O-Ring	Teflon®/Viton® O-Ring	Teflon®/Viton® O-Ring
Stem	ASTM A479-316	ASTM A479-316	ASTM A479-316
Packing Adjuster	ASTM A696 Gr.C	ASTM A696 Gr.C	ASTM A479-316
Packing Follower	ASTM A479-316	ASTM A479-316	ASTM A479-316
Jam Nut (TFE Packed Only)	ASTM A696 Gr.C	ASTM A696 Gr.C	ASTM A582-303
Handle Assembly	ASTM A108	ASTM A108	300 Series SS

Max Cv Ratings

.375" Orifice	Straight Body Style
	2.40

Approx. Manifold Weight:

- 9.00 lbs. [4.08 kg] ea. (M3-500)
- 7.00 lbs. [3.17 kg] ea. (M3-650)
- 7.60 lbs. [3.44 kg] ea. (M3-750)

* Barstock equivalent of ASTM A105

Notes

- PGI Carbon Steel products are Alkaline Zinc plated for corrosion prevention
- PGI 316 SS products meet the requirements of NACE MR0175/ISO 15156-3
- 100% Pressure Tested
- Carbon Steel Weld End Connection Bodies are ASTM A696 Gr.C



3-Valve Differential Pressure Manifolds

SOFT SEAT

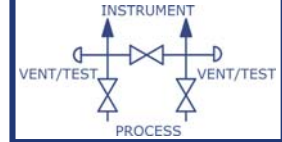

SOFT SEAT: .187" Orifice



Features

- PGI Soft Cone Seat

Benefits

- Roddable straight-through design
- Leak free, bubble tight seating
- Easily replaced
- Available in a variety of materials
- Bi-directional flow

Dimensions, inches [mm]

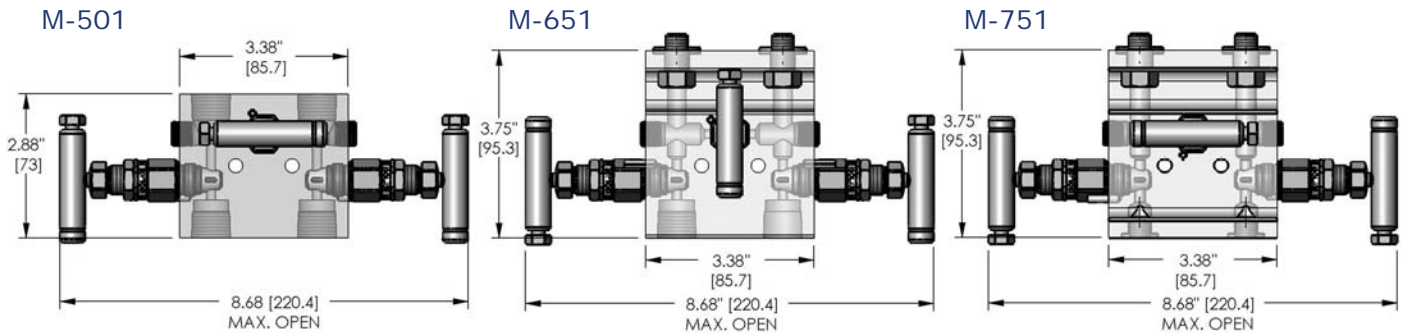

Pressure vs. Temperature

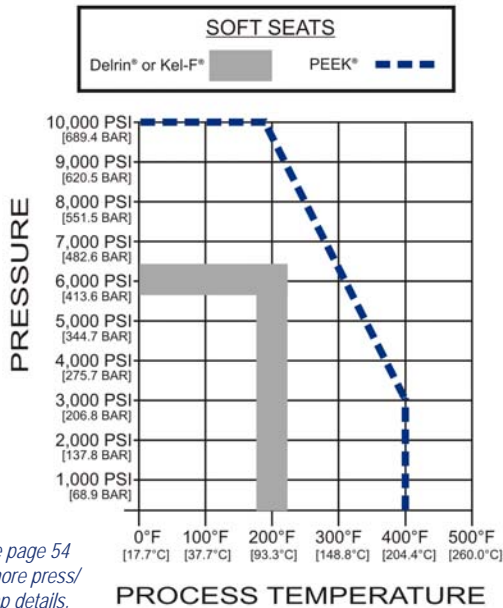

See page 54 for more press/temp details.

Part Number Selection

Base Model

		Process x Instrument x Vent
M-	501	1/2" FNPT x 1/2" FNPT x 1/4" NPT
M-	651	1/2" FNPT x Flange x 1/4" FNPT
M-	751	Flange x Flange x 1/4" NPT

Body Material Code

C	ASTM A108
S	ASTM A479-316 SS
S	ASTM A276-316 SS □
P	ASTM A696*

Seat Material Code

D	Delrin® (Standard)
K	Kel-F®
P	Peek®

Stem Packing/Seal Code

P	Teflon® (Below threads)
V	Viton® O-Ring

M- - Options [pages 49-50]

Materials of Construction

Part	Carbon Steel	A696 Carbon Steel*	316 Stainless Steel
Body / Bonnet	ASTM A108	ASTM A696 Gr.C	ASTM A479-316 ASTM A276-316 □
Packing "P" / "V"	Teflon®/Viton® O-Ring	Teflon®/Viton® O-Ring	Teflon®/Viton® O-Ring
Stem	ASTM A479-316	ASTM A479-316	ASTM A479-316
Packing Adjuster	ASTM A696 Gr.C	ASTM A696 Gr.C	ASTM A479-316
Packing Follower	ASTM A479-316	ASTM A479-316	ASTM A479-316
Jam Nut (TFE Packed Only)	ASTM A696 Gr.C	ASTM A696 Gr.C	ASTM A582-303
Handle Assembly	ASTM A108	ASTM A108	300 Series SS

Max Cv Ratings

.187" Orifice	Straight Body Style
	.83

Approx. Manifold Weight:

- 4.20 lbs. [1.90 kg] ea. (M-501)
- 5.20 lbs. [2.35 kg] ea. (M-651)
- 5.70 lbs. [2.58 kg] ea. (M-751)

* Barstock equivalent of ASTM A105

Notes

- PGI Carbon Steel products are Alkaline Zinc plated for corrosion prevention
- PGI 316 SS products meet the requirements of NACE MR0175/ISO 15156-3
- 100% Pressure Tested
- Carbon Steel Weld End Connection Bodies are ASTM A696 Gr.C



3-Valve Differential Pressure Manifolds

SOFT SEAT

SOFT SEAT: .375" Orifice



Features

- PGI Soft Cone Seat

Benefits

- Roddable straight-through design
- Leak free, bubble tight seating
- Easily replaced
- Available in a variety of materials
- Bi-directional flow

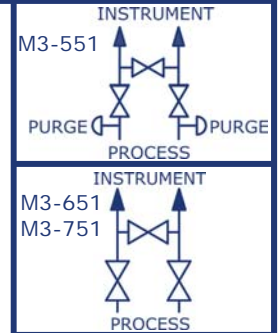

Dimensions, inches [mm]

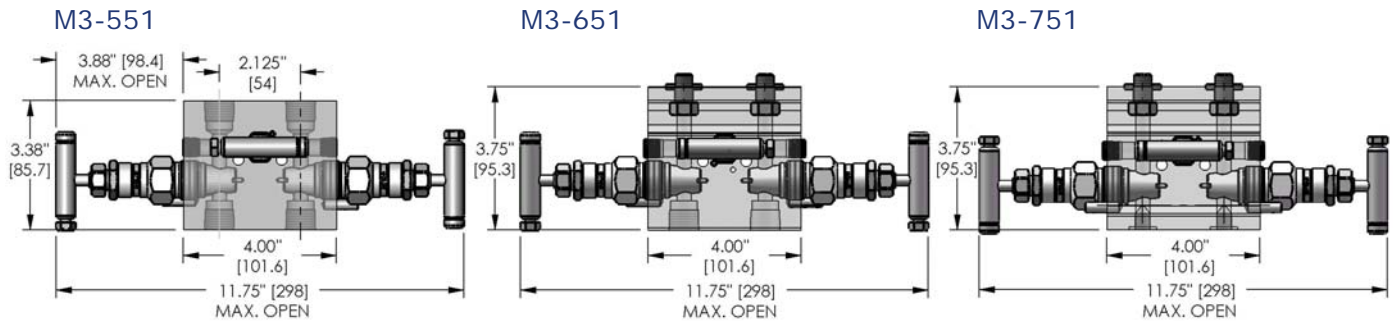

Pressure vs. Temperature

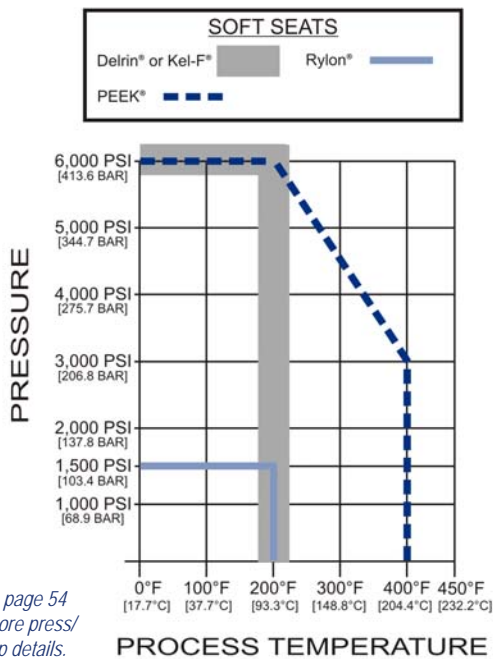

Part Number Selection

Base Model

		Process x Instrument x Vent
M3-	551	1/2" FNPT x 1/2" FNPT x 1/4" NPT
M3-	651	1/2" FNPT x Flange x 1/4" FNPT
M3-	751	Flange x Flange x 1/4" NPT

Body Material Code

C	ASTM A108
S	ASTM A479-316 SS
	ASTM A276-316 SS
P	ASTM A696*

Seat Material Code

L	Rylon™ (Standard)
D	Delrin®
K	Kel-F®
P	Peek®

Stem Packing/Seal Code

P	Teflon® (Below threads)
V	Viton® O-Ring

M3- - Options [pages 49-50]

Materials of Construction

Part	Carbon Steel	A696 Carbon Steel*	316 Stainless Steel
Body / Bonnet	ASTM A108	ASTM A696 Gr.C	ASTM A479-316 ASTM A276-316
Packing "P" / "V"	Teflon®/Viton® O-Ring	Teflon®/Viton® O-Ring	Teflon®/Viton® O-Ring
Stem	ASTM A479-316	ASTM A479-316	ASTM A479-316
Packing Adjuster	ASTM A696 Gr.C	ASTM A696 Gr.C	ASTM A479-316
Packing Follower	ASTM A479-316	ASTM A479-316	ASTM A479-316
Jam Nut (TFE Packed Only)	ASTM A696 Gr.C	ASTM A696 Gr.C	ASTM A582-303
Handle Assembly	ASTM A108	ASTM A108	300 Series SS

Max Cv Ratings

.375" Orifice	Straight Body Style
	2.4

Approx. Manifold Weight:

- 9.00 lbs. [4.08 kg] ea. (M-500)
- 7.00 lbs. [3.17 kg] ea. (M-650)
- 7.60 lbs. [3.44 kg] ea. (M-750)

* Barstock equivalent of ASTM A105

Notes

- PGI Carbon Steel products are Alkaline Zinc plated for corrosion prevention
- PGI 316 SS products meet the requirements of NACE MR0175/ISO 15156-3
- 100% Pressure Tested
- Carbon Steel Weld End Connection Bodies are ASTM A696 Gr.C