

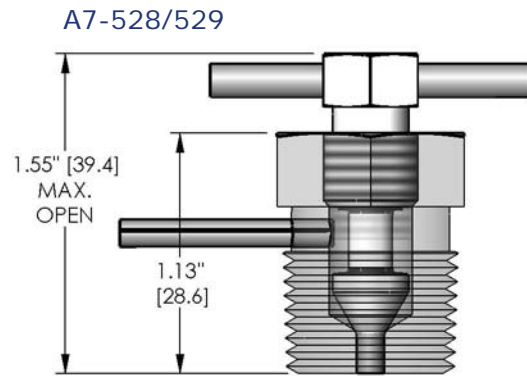

Bleeder Plugs

Dimensions, inches [mm]

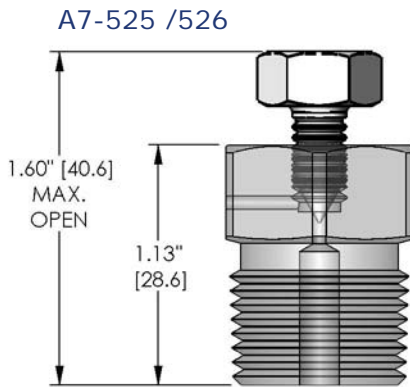
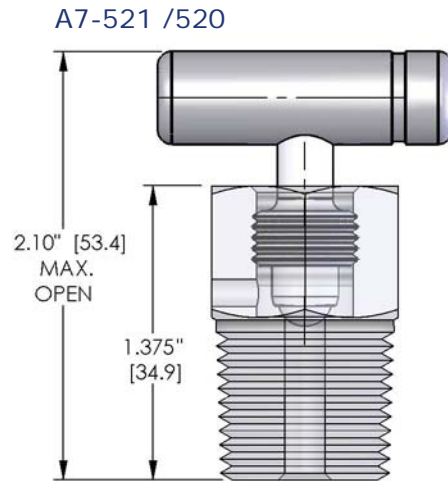
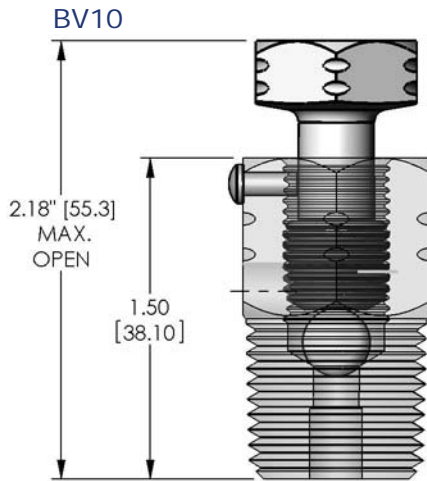

Part Number Selection

Base Model

	Connection	Seat Material	Other Material
BV10N2	1/4" MNPT	440 SS Ball	Drive Screw 300 SS
BV10N4	1/2" MNPT		
A7-520	1/2" MNPT	Carbide Ball	
A7-521	1/4" MNPT		
A7-525	1/4" MNPT	Integral Metal	Bleed Screw 316 SS
A7-526	1/2" MNPT		
A7-528	1/4" MNPT		Bleed Tube 316 SS
A7-529	1/2" MNPT		

Body Material Code

10	ASTM A108
C0	ASTM A479-316 SS



Pressure vs. Temperature

Carbon Steel	10,000 PSI @ 200° F Max 1,500 PSI @ 500° F Max
316 SS	10,000 PSI @ 200° F Max 1,500 PSI @ 1,000° F Max

Materials of Construction

See Body Material Code.

Weights

Approx. Valve Weight:
 .50 lbs. [.22 kg] ea. (BV10N2/N4)
 .50 lbs. [.22 kg] ea. (A7-520/521)
 .30 lbs. [.13 kg] ea. (A7-525/526)
 .50 lbs. [.22 kg] ea. (A7-528/529)

Notes

- PGI Carbon Steel products are Alkaline Zinc plated for corrosion prevention
- PGI 316 SS products meet the requirements of NACE MR0175/ISO 15156-3
- 100% Pressure Tested
- Carbon Steel Weld End Connection Bodies are ASTM A696 Gr.C



Bleed "T" Valves

Dimensions, inches [mm]

V-598

Shown with
B2 Option

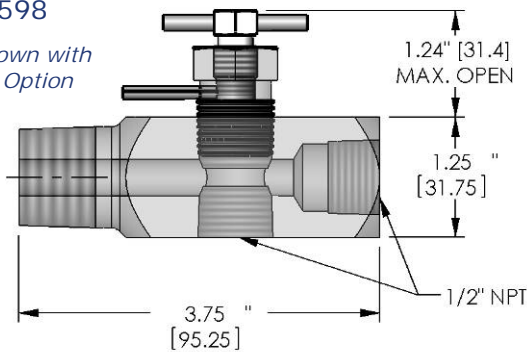

B1 Option

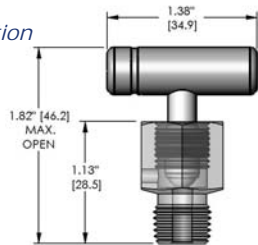

B2 Option

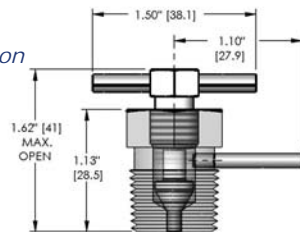

B4 Option

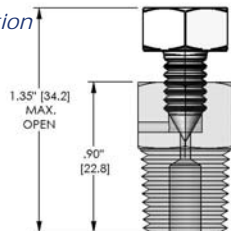

B6 Option

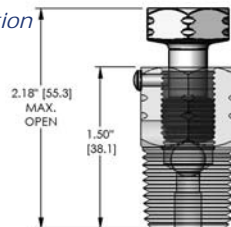

Part Number Selection

Base Model

Process x Instrument			
V-	597-	1/2" MNPT x (3) 1/2" FNPT	
V-	598-	3/4" MNPT x (3) 1/2" FNPT	
B8-	597-	1/2" MNPT x (3) 1/2" FNPT	Body Only
B8-	598-	3/4" MNPT x (3) 1/2" FNPT	Body Only

Body Material Code

10	ASTM A108
C0	ASTM A479-316 SS

Bleeder Installed

B1	Carbide Ball Bleed Plug (A7-520)
B2	Bleed "T" Plug (A7-529)
B4	Mini-Hex Bleed Plug (A7-526)
B6	SS Ball Bleed Plug (BV10N4)

Pressure vs. Temperature

Carbon Steel	10,000 PSI @ 200° F Max 1,500 PSI @ 500° F Max
316 SS	10,000 PSI @ 200° F Max 1,500 PSI @ 1,000° F Max

Materials of Construction

See Body Material Code.

Weights

Approx. Valve Weight:
1.00 lbs. [0.45 kg] ea. (V-597/598)
0.50 lbs. [0.22 kg] ea. (BX Options)

Notes

- PGI Carbon Steel products are Alkaline Zinc plated for corrosion prevention
- PGI 316 SS products meet the requirements of NACE MR0175/ISO 15156-3
- 100% Pressure Tested
- Carbon Steel Weld End Connection Bodies are ASTM A696 Gr.C