

# Meter Manifolds

**.187" ORIFICE**

## Description

1/4" FNPT x 1/4" FNPT

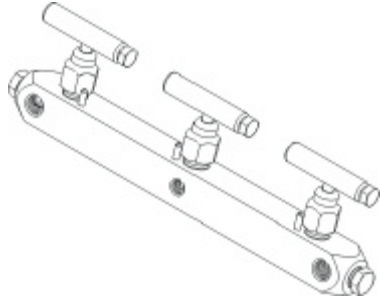

1/4" FNPT x 1/4" FNPT

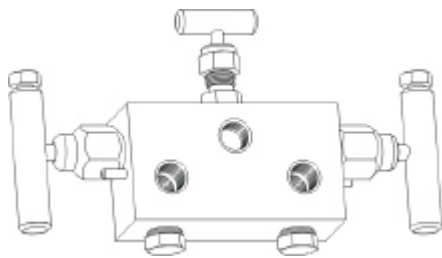

Flange x 1/4" FNPT

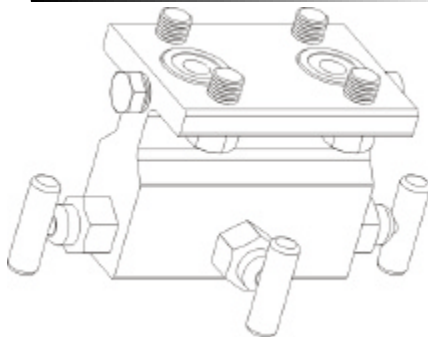

## Body Style

M-505 Soft Seat

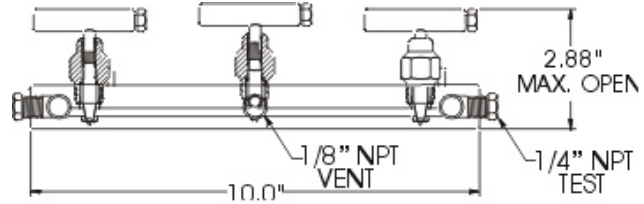

M-509 Soft Seat

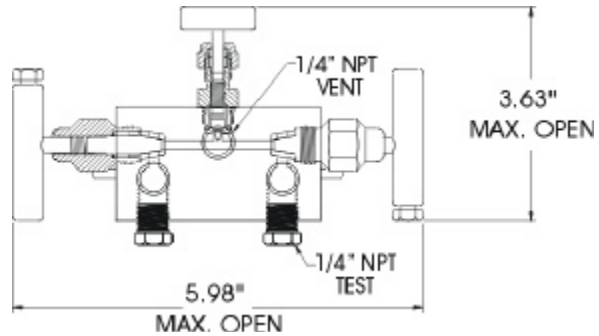

M-923 Soft Seat

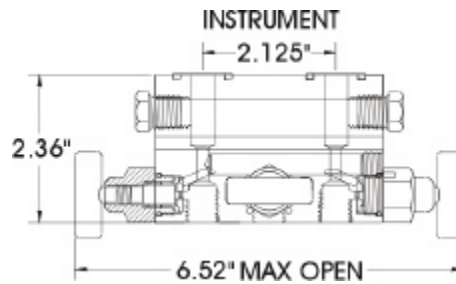

SEAT	MAX Cv RATINGS
Soft Cone	.83
Approx. Manifold Weight:	3.7 lbs each [M-505] 5.0 lbs each [M-509]

## MATERIALS OF CONSTRUCTION

PART DESCRIPTION	CARBON STEEL	316 SS	MONEL®	HASTELLOY-C®
Body	ASTM A108-1215	ASTM A479-316	Consult Factory.	Consult Factory.
Bonnet	ASTM A108-1215	ASTM A479-316		
Stem	ASTM A582-303	ASTM A479-316		
Seal Retainer	ASTM A479-316	ASTM A479-316		
Handle Assembly	ASTM A108	ASTM A582 (18-8)		
Plug(s)	ASTM A108	ASTM A182-F (18-8)		

- Carbon Steel Manifolds are Zinc Cobalt Plated with Dichromate Dip
- 316 SS Manifolds Meet NACE MR0175 Requirements (Latest Revision)
- 100% Pressure Tested

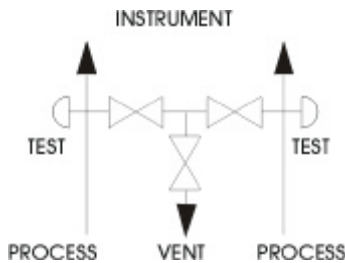

# Meter Manifolds

.187" ORIFICE

METER MANIFOLDS

## ORDERING INFORMATION

BODY STYLE	BODY CODE	SEAT CODE	STEM SEAL CODE	OPTION CODES				
Soft Seat								
M-505				-				
M-509				-				
M-923								

BODY CODE	
[Std.] Carbon Steel	C
[Std.] 316 SS	S

SOFT SEAT CODE	
D	Delrin® Cone/Washer [Std.]
K	Kel-F® Cone/Washer
P	PEEK® Cone/Washer
T	Teflon® Cone/Washer
Z	Tefzel Cone/Washer

STEM SEAL CODE	
[Std.] Teflon® Pressure-Core™	T
Viton® O-Ring	V
Low-Temp Pressure-Core™	J
Fluorosilicone Pressure-Core™	L

## OPTIONS

- Bonnet Lock Plates
- Bonnet Handle Lock-Out

See Options/Accessories Pages 61-62.

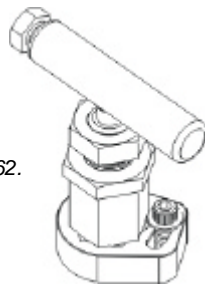

OPTION CODE	OPTION DESCRIPTION
C4	(2) .187" Orifice Block Valves - 1/4" NPT F x M V-501CDT/SDT
GA	Anti-Tamper Bonnet (All Positions - M-505 Only)
*GC	Anti-Tamper Bonnet (Isolate Valve(s) Only - M-505 Only)
GD	Anti-Tamper Bonnet (Equalizer Valve(s) Only - M-505 & M-509 Only)
GE	Anti-Tamper Bonnet (Vent Valve Only - M-505 Only)
GJ	Bonnet Lock-Out (All Positions - Lock Not Provided - M-505 Only)
*GK	Bonnet Lock-Out (Isolate Valve Only - Lock Not Provided - M-505 Only)
GL	Bonnet Lock-Out (Equalizer Valve(s) Only - Lock Not Provided - M-505 & M-509 Only)
GM	Bonnet Lock-Out (Vent Valve Only - Lock Not Provided - M-505 Only)
MH	Viton® O-Ring Flange Seals (M-923 Only)
W	Safety Bonnet Lock Plate
WK	Paper Tag
W1	316 SS Tag (20 Characters - See page 61)
XL	Clean for Critical Service (Oxygen or Chlorine)

\* Only with C4 Option on M-505.

## PRESSURE & TEMPERATURE

BODY MATERIAL	SOFT SEAT (Delrin)	SOFT SEAT (Delrin)
	M-505	M-509
Carbon Steel	6,000 PSI @ 200° F Max.	3,000 PSI @ 200° F Max.
316 SS	6,000 PSI @ 200° F Max.	3,000 PSI @ 200° F Max.

See Page 5:                      Chart B                      Chart C