

PRESSURE-CORE[®] SEAL

A SUPERIOR DESIGN FOR BETTER PERFORMANCE

ISO 9001:2008 Certified Quality System

Advanced Stem Seal System

Leak-Free Performance

No Adjustments or Maintenance Requirements

Unmatched 5 Year Warranty

No Fugitive Emissions

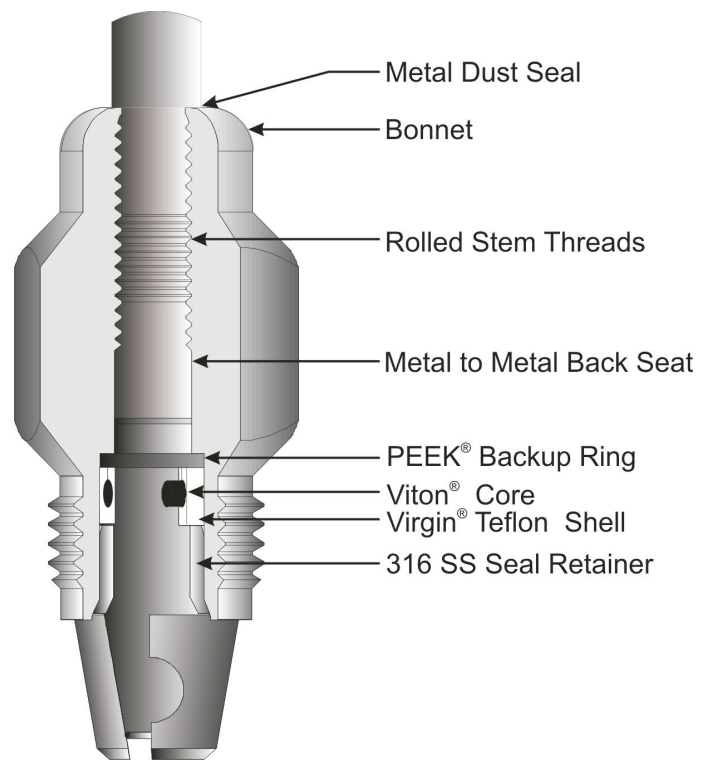

Five Year Warranty

PATENTED



PGI International

Excellence Through Innovation

PRESSURE-CORE® SEAL

How We Do It!

The Pressure-Core® Seal consists of an outer Teflon® shell with an elliptical shaped Viton® O-Ring core. The encapsulated core is “live-loaded” and provides constant outward pressure against the Teflon® shell, which flexes under pressure like an O-Ring. The Teflon® shell offers the desired chemical resistance without periodic gland tightening as in conventional designs.

Testing Proves It!

Compared to competitive bonnet designs, PGI's Pressure-Core® Seal offers leak-free performance with no maintenance requirements. To support this claim, the Pressure-Core® Seal was tested against the competitors' design. The tests simulated harsh plant operating environments and were performed by an independent laboratory in accordance with EPA Method 21.

Test results indicate that the Pressure-Core Seal is a reliable, affordable, virtually leak-free bonnet requiring no costly, time consuming maintenance. PGI stands behind this claim with a five year warranty, far exceeding the industry standard.

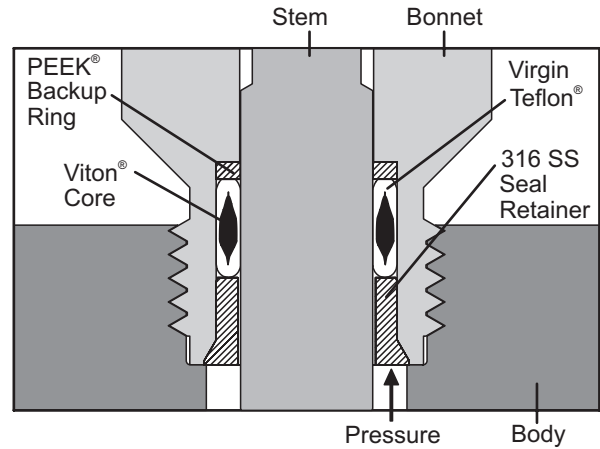

Fugitive Emissions Test Results

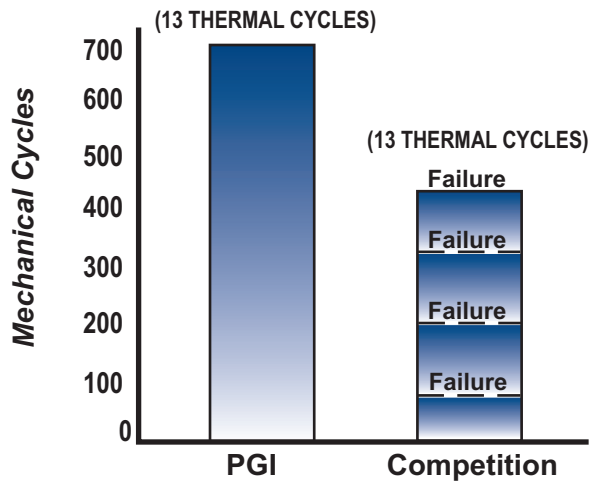

See for yourself how our Pressure-Core not only outperforms the competition, but sets a new industry standard...

TEST PROCEDURE

Valves mechanically cycled 50 times (full open to full close) at 1,000 PSI methane, then heated to 400°F and air cooled to ambient. Procedure repeated until failure.

FAILURE CRITERIA

100 PPM leak*

*Competition's Emission Seal Warranty

TEST RESULTS

PGI: The Pressure-Core Seal successfully completed **694** mechanical cycles and **13** thermal cycles. Maximum leakage throughout testing was 40 PPM.

Competition: The competition's "low emissions" graphite design failed on the **89th** mechanical cycle and on average every **125** cycles throughout the testing. Repeated maintenance was required between each failure to re-adjust the valve packing.

PGI International provides this information in good faith, and it is intended only as an informative guide to PGI International products and services. Individuals using this literature must exercise their independent judgment in evaluating product selection and determining product appropriateness for their particular purpose, system requirements and certifications. PGI International reserves the right to change product designs and specifications without notice.



PGI International
Excellence Through Innovation

16101 Vallen Drive • Houston, TX 77041 USA
713-466-0056 • 1-800-231-0233 • Fax: 1-800-568-9228
sales@pgiint.com • www.pgiint.com