

THERMO-ELECTRIC BATTERY CHARGER

— **LOW COST Continuous Reliable Power!** —

NEW & IMPROVED

- Ideal power source for critical automation and data applications like SCADA, flow computers, gas metering, volume correctors and odorization
- TEC's continuous power output...night, day, rain, sleet, snow or wind...results in lower system cost than equivalent solar panel system and equipment
- Output actually improves in harsh weather
 - TEC-2 produces 1.7 to 2.0 watts --
Equivalent to 14 to 40 watt solar panel
 - TEC-8 produces 6.3 to 7.3 watts --
Equivalent to 40 to 150 watt solar panel
- Operates on a very small volume of natural gas or propane:
 - TEC-2 uses: 1.0 CFH gas [0.03 M³/Hour]
0.33 CFH propane [0.01 M³/Hour]
 - TEC-8 uses: 3.0 CFH gas [0.08 M³/Hour]
1.0 CFH propane [0.03 M³/Hour]
- Microprocessor controlled for fast, easy "one button" startup
- Status output for remote monitoring
- 2" [5.08 cm] pipe or wall mountable
- CSA Approved for Class 1, Division 2, Group D hazardous locations. Evaluated to CSA and ANSI/UL standards for use in Canada and the United States

TEC-2™



TEC-8™



PGI International
Excellence Through Innovation

713-466-0056 800-231-0233
sales@pgiint.com www.pgiint.com

ISO 9001:2000 Certified Quality System



TEBC
Rev. 13
4-11-07

OVERVIEW

NEW and IMPROVED TEC-2 and TEC-8 Battery Chargers.

Wind, sleet, snow, rain, and dark of night. You can depend on TEC to deliver power to your data, communication, and automation applications. All you need is a little natural gas or propane.

TEC-2 and TEC-8 supply 12 and 24 volt batteries with up to 7.3 watts of continuous power, regardless of available sunlight that could limit solar panel applications.

TEC continuously charges lead acid batteries to always meet your power requirement regardless of available sunlight or inclement weather. TEC's small, robust, self-contained package makes installment quick and easy and virtually eliminates theft and vandalism. TEC extends its companion battery life by continually monitoring state-of-charge and temperature to optimize its charge and minimize deep battery cycles.

TEC: Continuous operation returns low cost, improved performance to equivalent solar panel/battery systems

TEC-2 generally produces from 1.7 to 2.0 watts of continuous power, depending on load, weather conditions, and altitude. That output is roughly equivalent to a 14 to 40-watt solar panel, depending on available sunlight. For example, a TEC-2 would be equivalent to a 20-watt solar panel stationed to receive 6 sun-hours per day or a 40-watt solar panel stationed to receive 2 sun-hours per day. Similarly, TEC-8 generally produces from 6.3 to 7.3 watts of continuous power, roughly equivalent to a 40 to 150-watt solar panel system under the same conditions.

TEC: No Large Safety Factor and No Uncertainty

Automation and communication systems at critical and remote locations demand sustained power and no down-time so costly safety factors must often be considered to ensure reliability. Solar panel systems generally require significant safety factors, including larger batteries and battery banks, to accommodate worst case scenarios and days with limited sunlight. Even then you may not be safe.

TEC eliminates the large safety factor considerations and delivers power regardless of weather conditions or sunlight. TEC continuously charges the battery while your application draws it down and then goes into "sleep mode" when the battery is once again fully charged. TEC's controlled, continuous feed eliminates deep battery cycles that shorten battery life. With TEC, simply select the battery required to handle application power surges, hit the fast "one button" startup switch, and let it run. No worries.

How Does TEC Work?

TEC uses the same safe, reliable catalyst technology that has been heating equipment in the natural gas industry for over 30 years. The package is Class 1, Division 2 approved and could be installed in almost any location where natural gas and propane are available. The units consume a small amount of fuel [TEC-2 uses 1.0 CFH gas (0.03 M³/Hour) or 0.33 CFH propane (0.01 M³/Hour); TEC-8 uses 3.0 CFH gas (0.08 M³/Hour) or 1.0 CFH propane (0.03 M³/Hour)] in a recently improved flameless oxidizing catalyst.

The catalyst heats one side of an array of peltier thermoelectric modules while the other side is cooled by natural convection through aluminum fins to the environment. The temperature difference developed across the modules generates safe, electrical power.

TEC's self-contained starting system for the catalytic heater makes starting as simple as flipping a switch to turn the system ON and pressing a button to open the gas safety valve. The generated power is conditioned by a high efficiency switching power supply to provide the ideal temperature compensated battery charging current and voltage to the battery.

Internal diagnostics detect possible system problems, while alarm codes and charger state are saved in non-volatile memory to assist in trouble shooting. You can remotely monitor the system status using the open collector alarm output.

TEC-2 can easily power transmitters and most flow computers, while TEC-8 may be your choice for larger applications such as communications and automation packages. Multiple TEC units can be run in parallel to power larger requirements.

Download PGI's Power Requirements Worksheet from our website at www.pgiint.com/thermoelectric.asp to determine which system is right for your application.

PRODUCT WARRANTY

PGI International warrants its products to be free from defects in material and/or workmanship for a period of one (1) year from date of shipment. This guarantee is valid only if such products have been used in normal applications consistent with our recommendations. Our liability is limited to repair or replacement and no responsibility is assumed for consequential damage or expense. Any controversy arising out of the sale of PGI International products shall be determined in accordance with the laws of the State of Texas, United States of America (USA). PGI International reserves the right to change materials, specifications or designs without notice. PGI International will not be obligated to install or furnish such changes on products previously sold.

TEC-2

DIMENSIONS

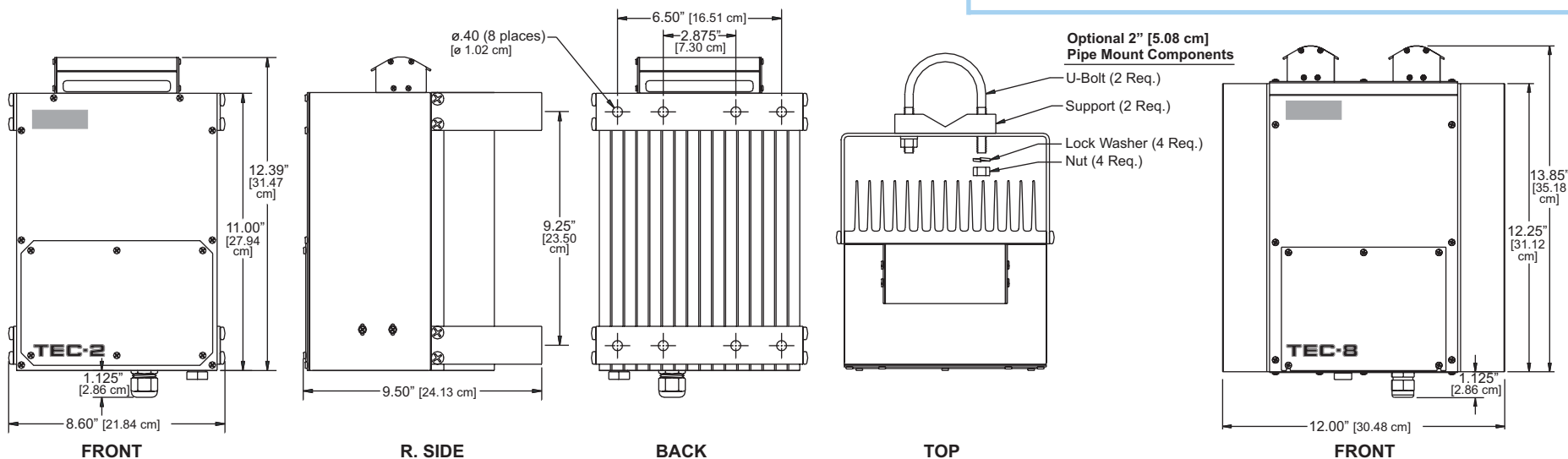

A complete system includes the charger in a 304 SS enclosure, mounting hardware, supply shut-off valve with strainer, Battery Interface Module and a 20' [6.09 m] Battery Interface Harness.

MODEL OPTIONS

TEC-2	-XXXXXXXX
TEC-8	-XXXXXXXX
* TEC-2C	-XXXXXXXX
* TEC-8C	-XXXXXXXX

*Canada Only -
Max 15 PSI Inlet Pressure

AVAILABLE OPTIONS

- D = External Diagnostic Interface (allows connection of diagnostic cable without removing front cover)
- F = 50' [15.24 meters] Battery Interface Harness (Replaces std 20' [6.09 m])
- P1 = CS 2" [5.08 cm] U-bolts & nuts for mounting
- P2 = SS 2" [5.08 cm] U-bolts & nuts for mounting
- R = Propane Fuel Orifice
- S = Wire Screen Heat Shield (Prevents contact with top of unit)
- T = Tamper Resistant Hardware
- U = Strainer Only, Less Shut-Off Valve
- V = 24 Volt System (12V Standard)

SPECIFICATIONS

Charger Output	Temperature compensated charge curve for 12 volt gel-cell standard; Optional 24 volt curve & constant voltage available
Output Power	TEC-2: Greater than 1.7 Watts continuous at 68°F ambient (20°C) TEC-8: Greater than 6.3 Watts continuous at 68°F ambient (20°C)
Remote Battery Temp Sensor	Silicone diode with 12' of cable
Alarm	LED Monitor; NPN open collector, 30V max, 200mA max
Transient Protection	Bi-directional TVS, 1500 Watt peak pulse power dissipation; 1 Amp PTC over current protection
Electrical Connections	Liquid tight wire fitting; Can be removed to allow for 1/2" conduit fitting
Wire Connections	Screw cage clamp; 14 AWG Max
Fuel Connection	1/4" FNPT, 0.5 to 250 PSI [0.34 to 17.22 bar]
Fuel Consumption	Natural Gas: TEC-2: 24 cubic feet per day [0.68 M ³ /Day] TEC-8: 72 cubic feet per day [2.04 M ³ /Day] Propane: TEC-2: 0.22 gallons per day [0.87 liters/day; 1 pound/day] TEC-8: 0.66 gallons per day [2.50 liters/day; 3 pounds/day]
Operating Temp Range	-40°C (-40°F) to 50°C (120°F)
Enclosure	NEMA 3R; Wall mount or optional 2" [5.08 cm] pipe mount TEC-2 and TEC-8: 304 SS with anodized aluminum cooling fins
Weight	TEC-2: 22 pounds [9.97 kg] TEC-8: 50 pounds [22.67 kg]
Gas BTU Range	900 - 1100 BTU/Cu. Ft. Natural Gas [31,783-38,845 BTU/M ³] 2400 - 2600 BTU/Cu. Ft. Propane [84,755-91,817 BTU/M ³] (Consult factory for gas supply outside this range)

VISIONS

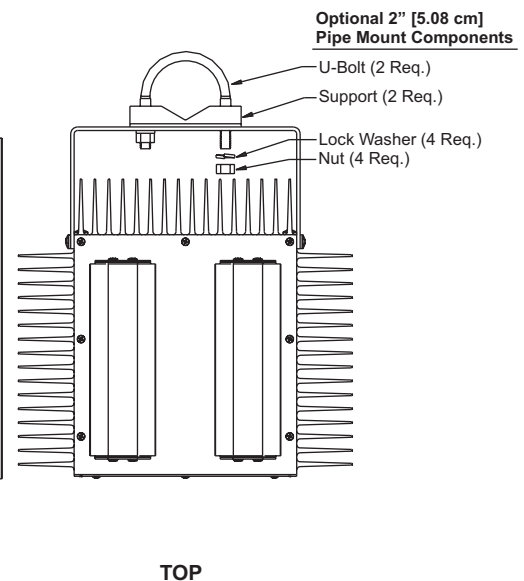
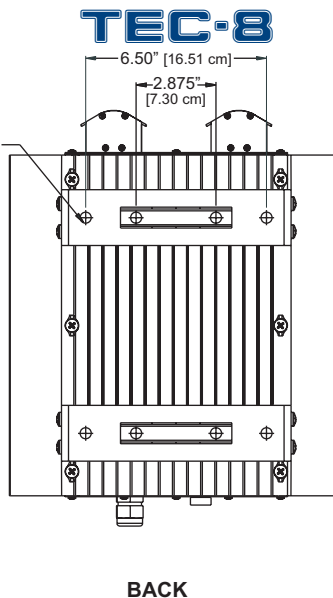
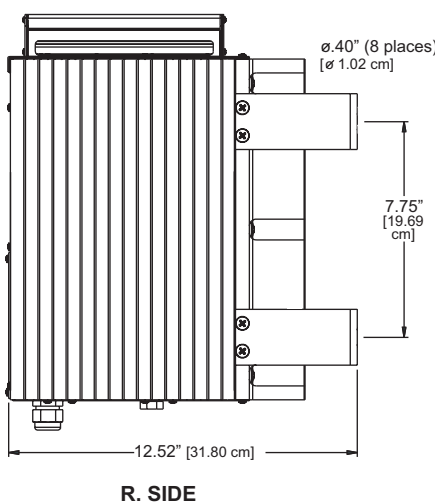
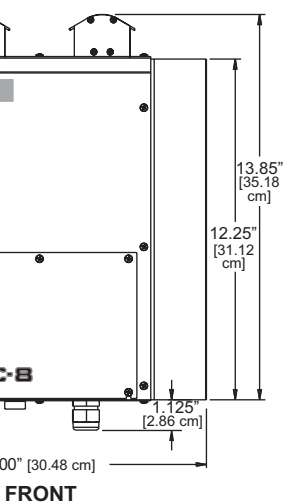

FRONT

R. SIDE

BACK

TOP

