

# Root Valves ~ Hard Seat

## ORIFICE

**.187" .375"**

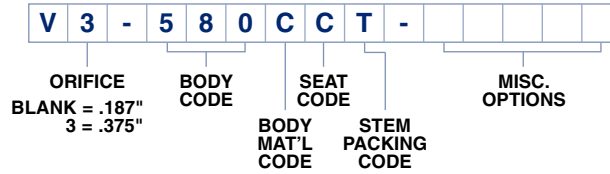

### V3-580

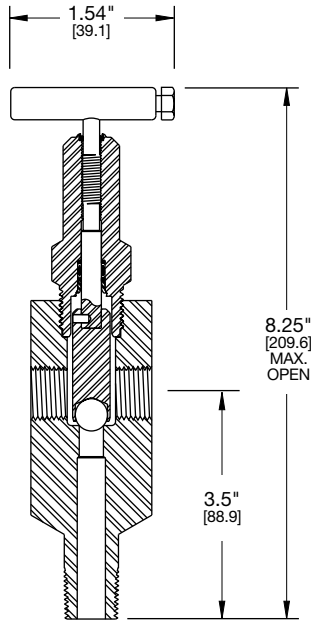

## ORDERING INFORMATION

PART NO.	CONNECTIONS		BODY & BONNET	SEAT & PACKING
	INLET	OUTLET		
<b>.187" Orifice</b>				
V-579CCT	1/2" MNPT	(1) 1/2" FNPT	Carbon Steel	Carbide Ball Seat
V-579SCT	1/2" MNPT	(1) 1/2" FNPT	316 SS	
V-580CCT	1/2" MNPT	(2) 1/2" FNPT	Carbon Steel	
V-580SCT	1/2" MNPT	(2) 1/2" FNPT	316 SS	
V-582CCT	3/4" MNPT	(2) 1/2" FNPT	Carbon Steel	Teflon® Pressure-Core® Stem Seal
V-582SCT	3/4" MNPT	(2) 1/2" FNPT	316 SS	
V-584CCT	1" MNPT	(2) 1/2" FNPT	Carbon Steel	
V-584SCT	1" MNPT	(2) 1/2" FNPT	316 SS	
<b>.375" Orifice</b>				
V3-579CCT	1/2" MNPT	(1) 1/2" FNPT	Carbon Steel	Max Pressure 6,000 PSI @ 200°F
V3-579SCT	1/2" MNPT	(1) 1/2" FNPT	316 SS	
V3-580CCT	1/2" MNPT	(2) 1/2" FNPT	Carbon Steel	
V3-580SCT	1/2" MNPT	(2) 1/2" FNPT	316 SS	
V3-582CCT	3/4" MNPT	(2) 1/2" FNPT	Carbon Steel	
V3-582SCT	3/4" MNPT	(2) 1/2" FNPT	316 SS	
V3-584CCT	1" MNPT	(2) 1/2" FNPT	Carbon Steel	
V3-584SCT	1" MNPT	(2) 1/2" FNPT	316 SS	

## MATERIALS OF CONSTRUCTION

PART DESCRIPTION	CARBON STEEL	316 SS
Body	ASTM A105 CF	ASTM A479-316 SS
Bonnet	ASTM A105	ASTM A351-CF8M
Stem	ASTM A479-316 SS	ASTM A479-316 SS
Yoke	ASTM A351-CF8M	ASTM A351-CF8M
Packing Follower	ASTM A479-316 SS	ASTM A479-316 SS
Bolt	ASTM A449-TYPE 1-CS	ASTM A193-B8M
Handle Assembly	ASTM A108 CS	ASTM A581 18-8 300 SS

- PGI Carbon Steel Products are Alkaline Zinc plated for corrosion prevention.
- PGI 316 SS Products meet the requirements of NACE MR0175/ISO 15156-36.
- 100% Pressure Tested

OPTION CODE	DESCRIPTION	
<b>Seat Material Options</b>		
R	Ceramic Ball Seat	Refer to Charts C and E on Page 22 and Pressure and Process Temperature Charts on Page 23.
6	316 SS Ball Seat	
<b>Stem Packing Material Option</b>		
T	Teflon® Pressure-Core® Stem Seal	
G	Low-Torque™ Grafoil® Packed	
J	Teflon® Pressure-Core® Stem Seal (Low Temperature -50°F)	
<b>Miscellaneous Options</b>		
AM7	Male Pipe Socket Weld - Male Inlet Only	
TH	Hydrostatic Testing	
W	Safety Bonnet Lock Plate (Lock Pin Standard)	
W1	316 SS Tag	
WK	Paper Tag	
XL	Clean for Critical Service (Oxygen or Chlorine)	

## MAX Cv RATINGS

ORIFICE SIZE	BODY STYLE Straight
.187"	.53
.375"	3.00

Approximate Valve Weight: 3.70 lbs [1.68 kg] each (.187" Orifice)  
4.50 lbs [2.04 kg] each (.375" Orifice)